



54790 Grand River Avenue, New Hudson MI. 48165

Phone: 248-573-4934

www.icomnorthamerica.com

email: info@icomnorthamerica.com

The ICOM JTG[®] II Mono Fuel Propane Liquid Injection System is EPA Certified for the 6.8L and 7.3L Ford E350 / E450 Shuttles and Cutaway / Stripped Chassis.



Go Green and Dramatically Reduce Fuel Costs!



The patented ICOM JTG[®] II Propane Liquid Injection System is innovative and offers these advantages:

- Nationwide Installation and Service
- Equal power, torque and drivability of gasoline
- Cold climate reliability
- Reduces greenhouse gas emissions by up to 20%
- Dramatically reduced emissions
- Virtually no particulates
- Extended service intervals
- Vehicle warranty remains in effect



EPA Certified

E350 & E450 Tank Options:

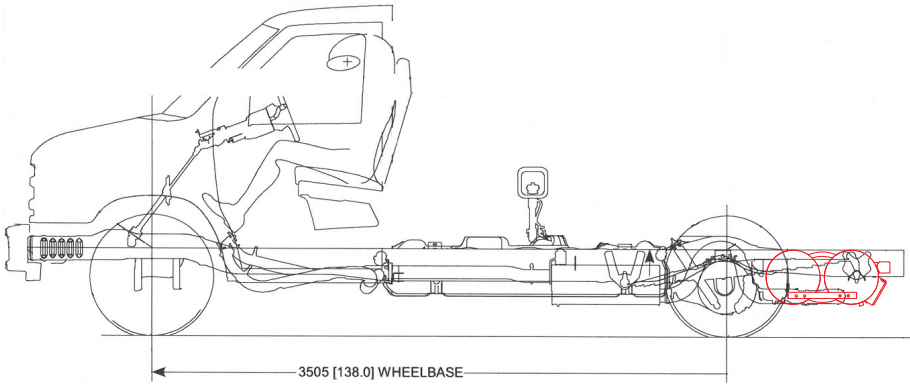

138" Wheelbase (Mid-Ship Gasoline Tank)



13 x 13 x 32 Under Vehicle Fuel Tank - 25.5 USG

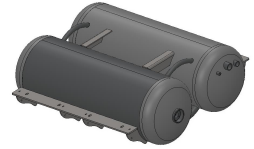

16 x 16 x 47 Under Vehicle Fuel Tank - 57 USG

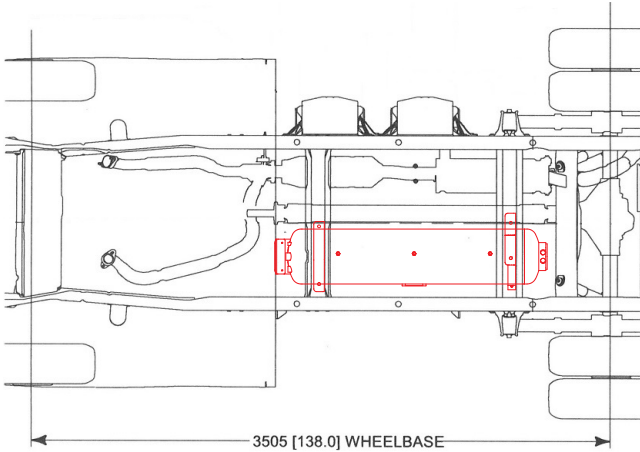

**138" Wheelbase (Rear Mount Gasoline Tank)
13 x 60 Under Vehicle Fuel Tank - 25 USG**

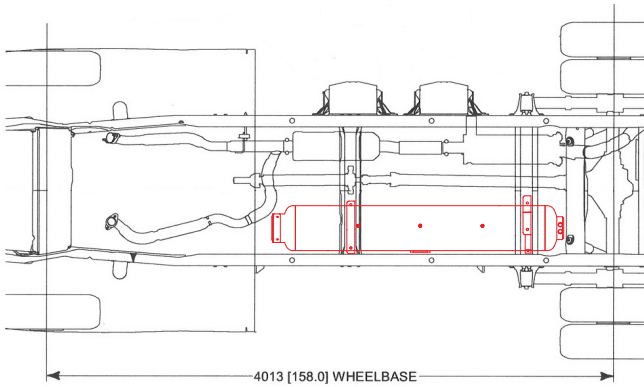

**158" Wheelbase
13 x 80 Under Vehicle Fuel Tank - 33.5 USG**

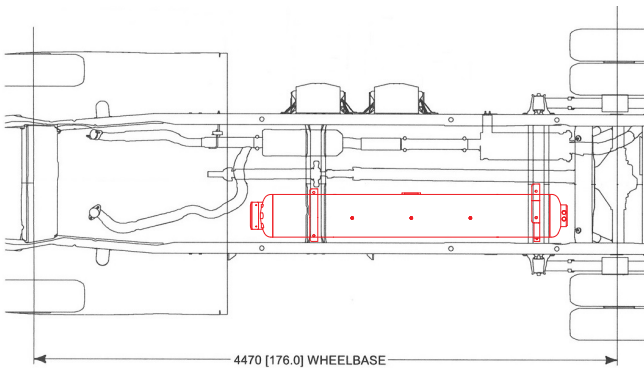
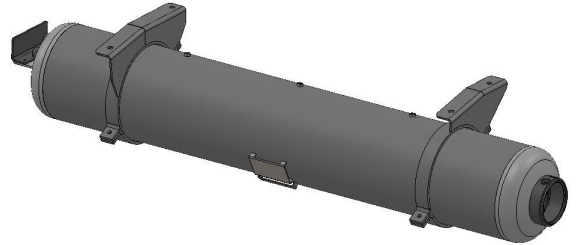

**176" Wheelbase and Longer
13 x 92 Under Vehicle Fuel Tank - 38.5 USG**

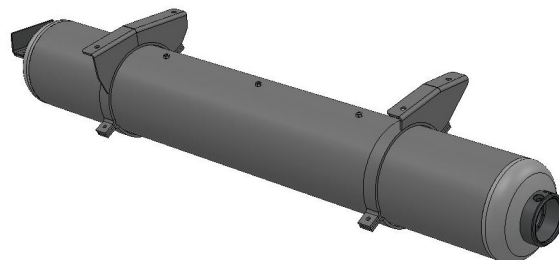

*** Contact ICOM for special tank and dual fuel tank applications**