



54790 Grand River Avenue, New Hudson MI. 48165  
Phone: 248-573-4934  
www.icomnorthamerica.com  
email: info@icomnorthamerica.com

The ICOM JTG® II Bi Fuel Propane Liquid Injection System is EPA Certified for the 2011 to 2020 Ford 6.2L and 7.3L F250 / F350. ICOM has the industry leading EPA Certified vehicle platforms with over 1000 to date.

**Go Green and Dramatically Reduce Fuel Costs!**



EPA Certified



**Optional - ICOM's 'Propane Optimization Program' (POP) eliminates driver input to maximize propane usage**

The patented ICOM JTG® II Liquid Propane System is innovative and offers these advantages:

- Nationwide Installation and Service
- Equal power, torque and drivability of gasoline
- Cold climate reliability
- Reduces greenhouse gas emissions by up to 20%
- Dramatically reduced emissions
- Virtually no particulates
- Fuel range extended with the use of bi-fuel
- Extended service intervals
- Vehicle warranty remains in effect



# Fuel Tank Options:

12 x 60 - 12 x 48 Under Tool Box In Bed Fuel Tank (Short Bed) - 38 USG  
 12 x 12 x 60 Under Tool Box In Bed Fuel Tank (Long Bed) - 42 USG

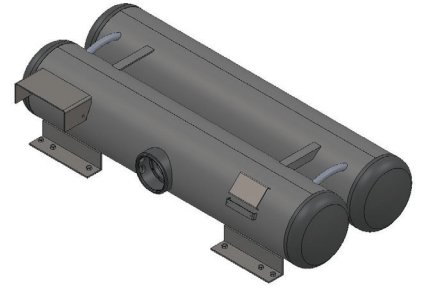
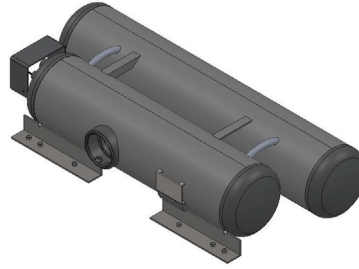
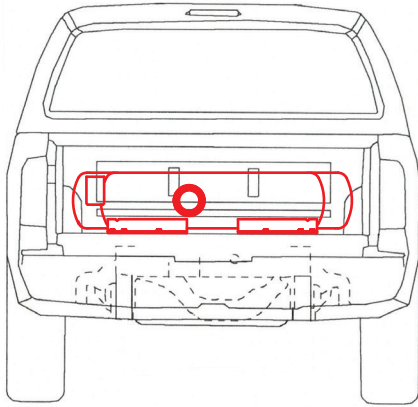

20 x 50 In Bed Fuel Tank (Short Bed) - 48 USG  
 20 x 60 In Bed Fuel Tank (Long Bed) - 57 USG

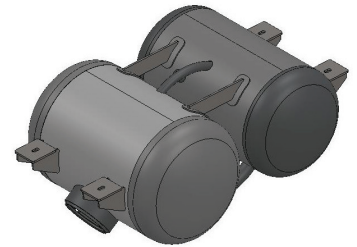
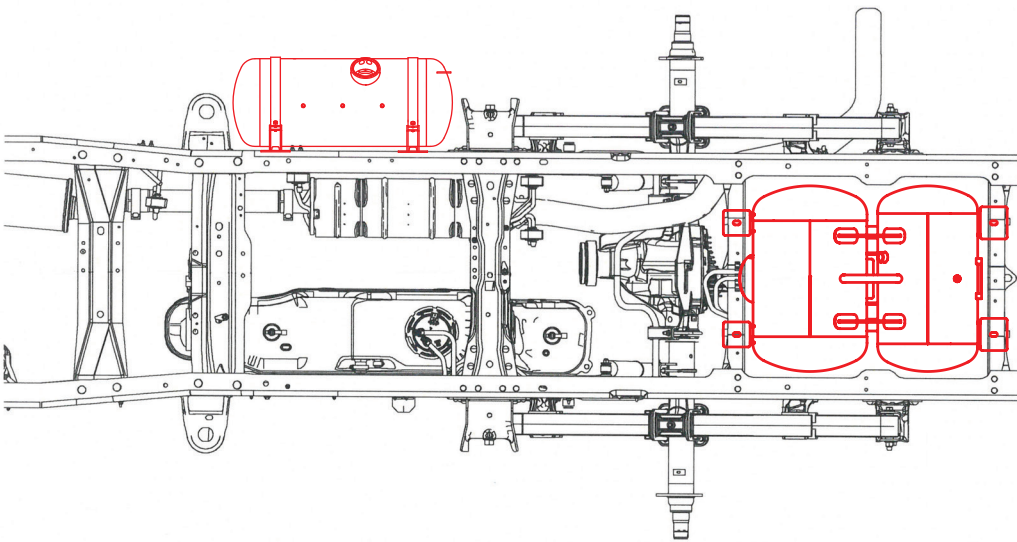
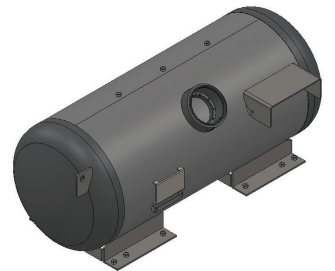
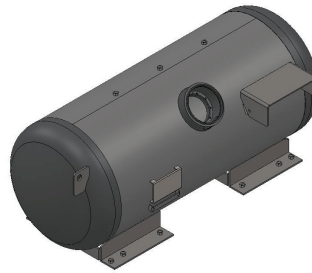
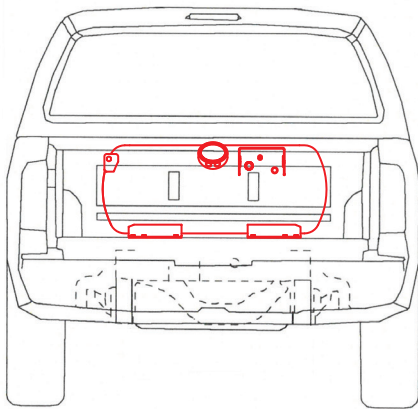

14 x 16 x 26 Under Vehicle Fuel Tank - 27 USG

*\* Service bodies only*

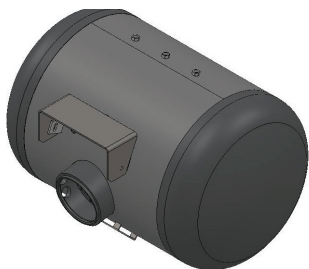

20 x 32 Saddle Mount Fuel Tank - 29 USG

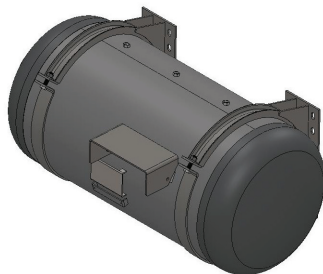

20 x 44 Saddle Mount Fuel Tank - 41 USG



720 x 270 Under Vehicle Toroidal Fuel Tank - 19 USG



14 x 14 x 31 Under Vehicle Fuel Tank - 28 USG