



54790 Grand River Avenue, New Hudson MI. 48165
Phone: 248-573-4934
www.icomnorthamerica.com
email: info@icomnorthamerica.com

The ICOM JTG® II Bifuel & Monofuel Propane Liquid Injection System is EPA Certified for the 2011 to 2021 Ford 6.8L F450/F550/F600/F650.

Go Green and Dramatically Reduce Fuel Costs!



Optional - ICOM's 'Propane Optimization Program' (POP) eliminates driver input to maximize propane usage

The patented ICOM JTG® II Propane Liquid Injection System is innovative and offers these advantages:

- Nationwide Installation and Service
- Equal power, torque and drivability of gasoline
- Cold climate reliability
- Reduces greenhouse gas emissions by up to 20%
- Dramatically reduced emissions
- Virtually no particulates
- Fuel range extended with the use of bi-fuel
- Extended service intervals
- Vehicle warranty remains in effect



Fuel Tank Configurations & Sizes:

1) In-Bed Options

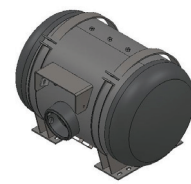
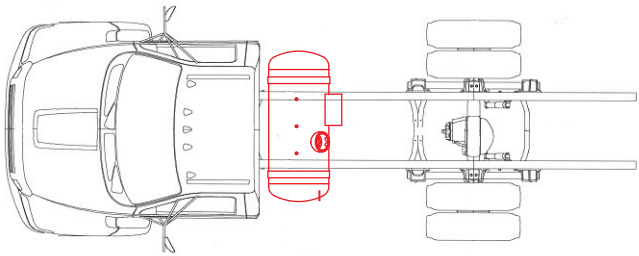

20 x 32 Fuel Tank - 29 USG

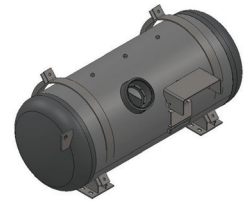

20 x 50 Fuel Tank - 48 USG

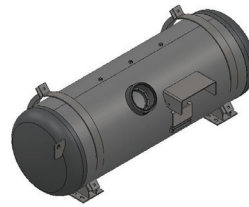

20 x 60 Fuel Tank - 57 USG

2) Frame Mount Options

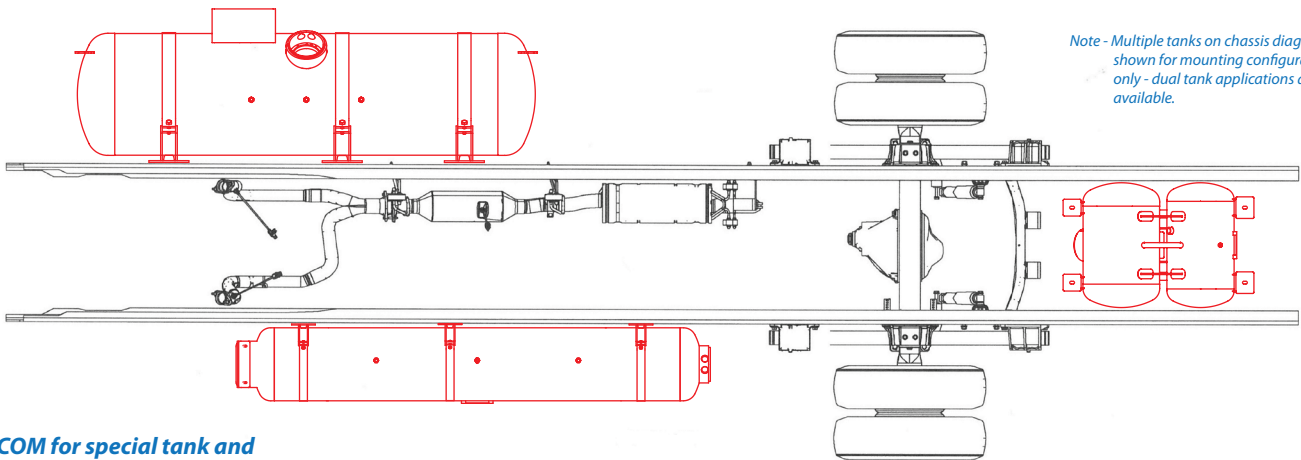

Note - Multiple tanks on chassis diagram shown for mounting configurations only - dual tank applications are available.

* Contact ICOM for special tank and dual fuel tank applications



13 x 60 Fuel Tank - 25 USG

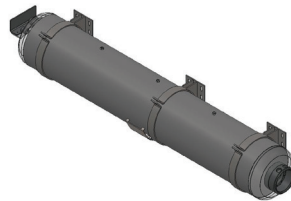

13 x 80 Fuel Tank - 33.5 USG

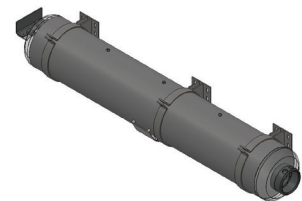

13 x 92 Fuel Tank - 38.5 USG

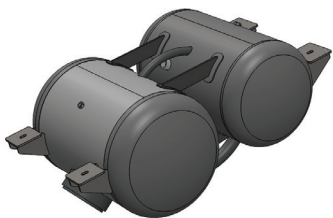

14 x 16 x 26 Fuel Tank - 27 USG

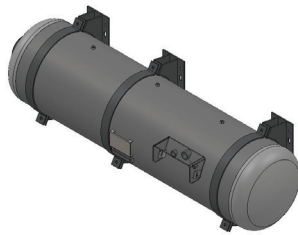

18 x 70 Fuel Tank - 55 USG

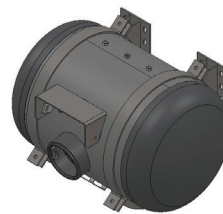

20 x 32 Fuel Tank - 29 USG

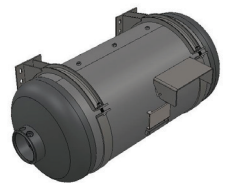

20 x 44 Fuel Tank - 41 USG

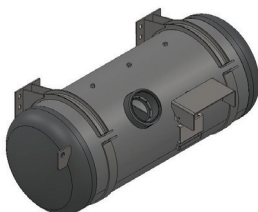

20 x 50 Fuel Tank - 48 USG

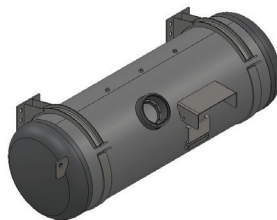

20 x 60 Fuel Tank - 57 USG

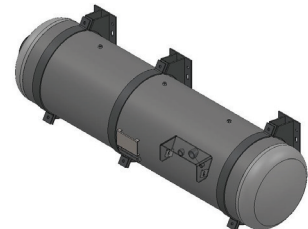

20 x 75 Fuel Tank - 73 USG