



54790 Grand River Avenue, New Hudson MI. 48165
Phone: 248-573-4934
www.icomnorthamerica.com
email: info@icomnorthamerica.com

The ICOM JTG® II Bi Fuel Propane Liquid Injection System is EPA Certified for the 2011 to 2019 Ford 6.8L F53 & F59 chassis. ICOM has the industry leading EPA Certified vehicle platforms with over 1000 to date.

***Go Green and Dramatically
Reduce Fuel Costs!***



EPA Certified



Optional - ICOM's 'Propane Optimization Program' (POP) eliminates driver input to maximize propane usage

The patented ICOM JTG® II Propane Liquid Injection System is innovative and offers these advantages:

- Nationwide Installation and Service
- Equal power, torque and drivability of gasoline
- Cold climate reliability
- Reduces greenhouse gas emissions by up to 20%
- Dramatically reduced emissions
- Virtually no particulates
- Fuel range extended with the use of bi-fuel
- Extended service intervals
- Vehicle warranty remains in effect



Fuel Tank Configurations & Sizes:

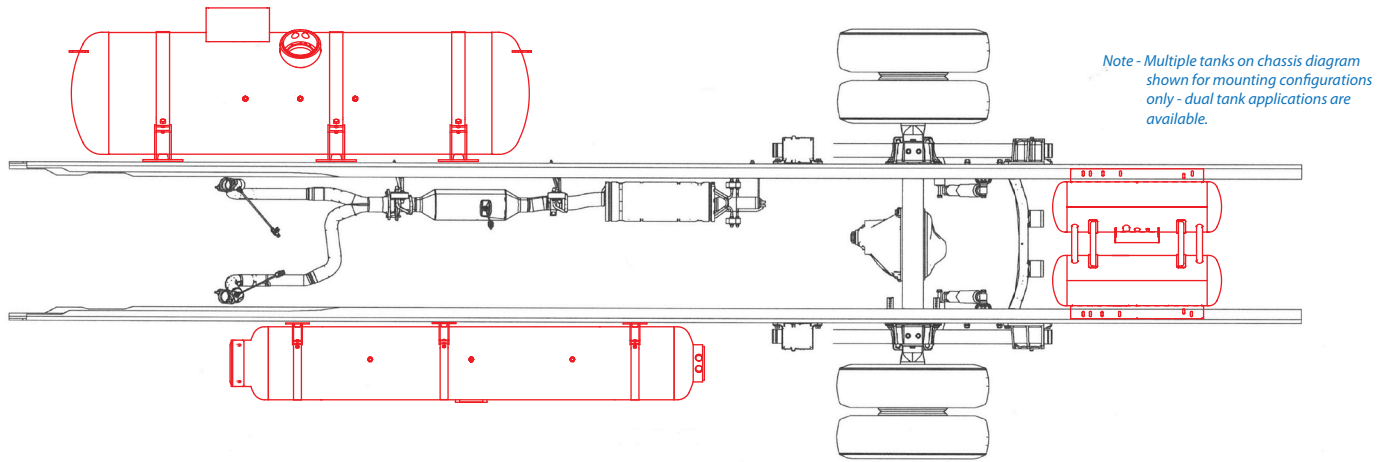

13 x 60 Fuel Tank - 25 USG

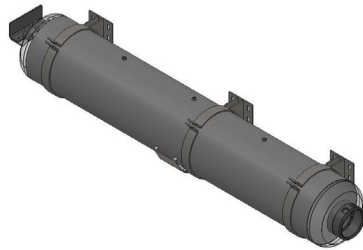

13 x 80 Fuel Tank - 33.5 USG

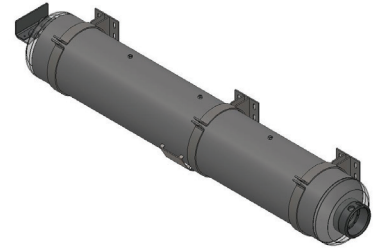

13 x 92 Fuel Tank - 38.5 USG

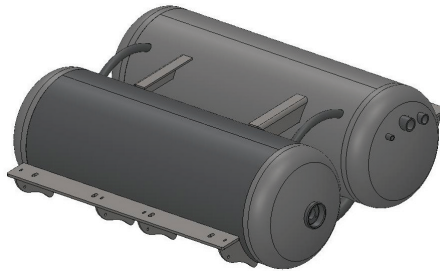

16 x 16 x 47 Fuel Tank - 57 USG

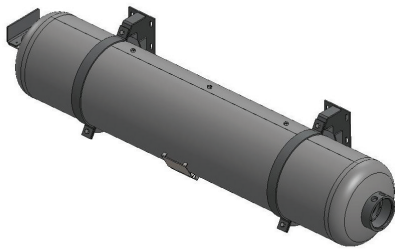

16 x 80 Fuel Tank - 50 USG

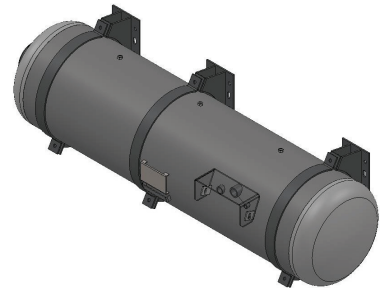

18 x 70 Fuel Tank - 55 USG

*** Contact ICOM for special tank and dual fuel tank applications**