



54790 Grand River Avenue, New Hudson MI. 48165  
Phone: 248-573-4934  
[www.icomnorthamerica.com](http://www.icomnorthamerica.com)  
email: [info@icomnorthamerica.com](mailto:info@icomnorthamerica.com)

**The ICOM JTG® II Bifuel & Monofuel Propane Liquid Injection System  
is EPA Certified for the Ford 6.8L and 7.3L F750.**

***Go Green and Dramatically  
Reduce Fuel Costs!***



**Optional - ICOM's 'Propane Optimization Program' (POP)  
eliminates driver input to maximize propane usage**

**The patented ICOM JTG® II Propane Liquid Injection System is innovative and offers  
these advantages:**

- Nationwide Installation and Service
- Equal power, torque and drivability of gasoline
- Cold climate reliability
- Reduces greenhouse gas emissions by up to 20%
- Dramatically reduced emissions
- Virtually no particulates
- Fuel range extended with the use of bi-fuel
- Extended service intervals
- Vehicle warranty remains in effect



EPA Certified

## Fuel Tank Configurations & Sizes:

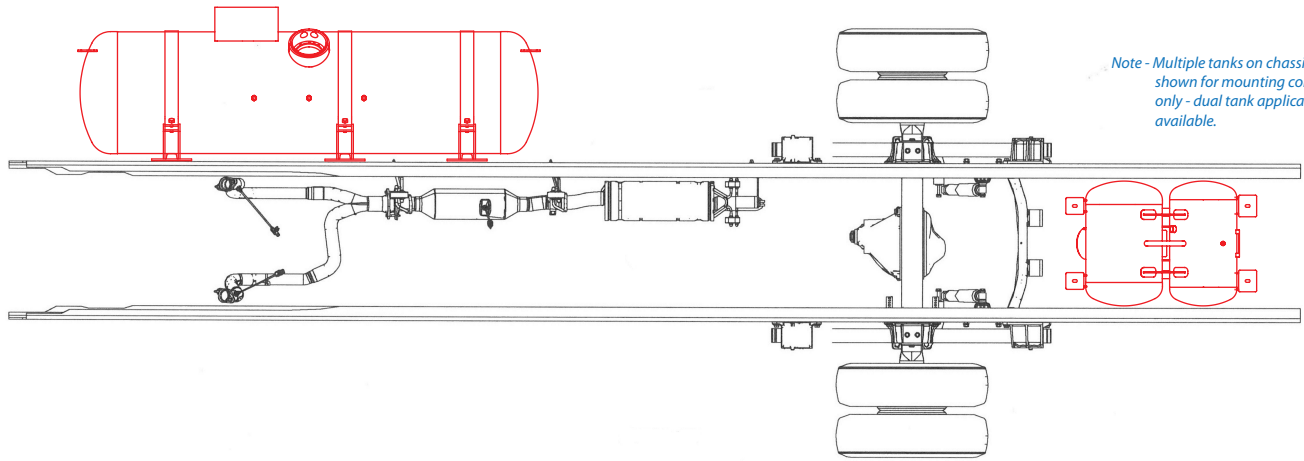

Note - Multiple tanks on chassis diagram shown for mounting configurations only - dual tank applications are available.

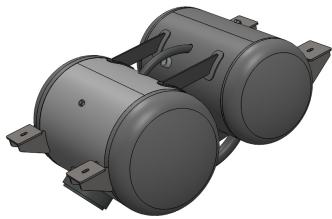

14 x 16 x 26 Fuel Tank - 27 USG

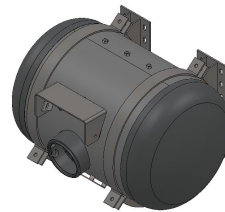

20 x 32 Fuel Tank - 29 USG

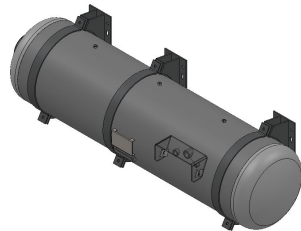

18 x 70 Fuel Tank - 55 USG

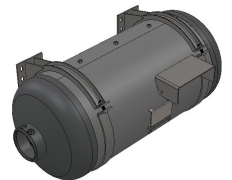

20 x 44 Fuel Tank - 41 USG

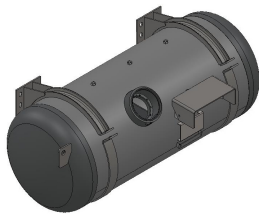

20 x 50 Fuel Tank - 48 USG

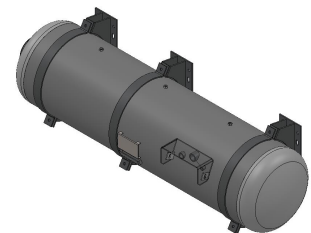

20 x 75 Fuel Tank - 73 USG

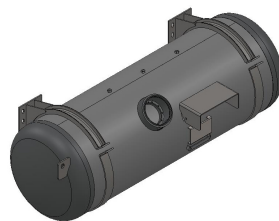

20 x 60 Fuel Tank - 57 USG

**\* Contact ICOM for special tank and dual fuel tank applications**