

Transit Cutaway & Chassis Cab

CUTAWAY & CHASSIS CAB		BODY TYPES						
		T250	T250	T350	T350	T350	T350	T350
		138" WB	156" WB	138" WB	138" WB	156" WB	156" WB	178" WB
FUEL TANKS	12 x 30 - 10 x 30.5 (17.5 USG)	X	X	X	X	X	X	X
	720 x 270 TOROIDAL (19 USG)	X	X	X	X	X	X	X
	14 x 14 x 31 (28 USG)	-	X	-	-	X	X	X

138" Wheelbase Van

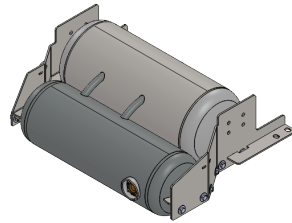
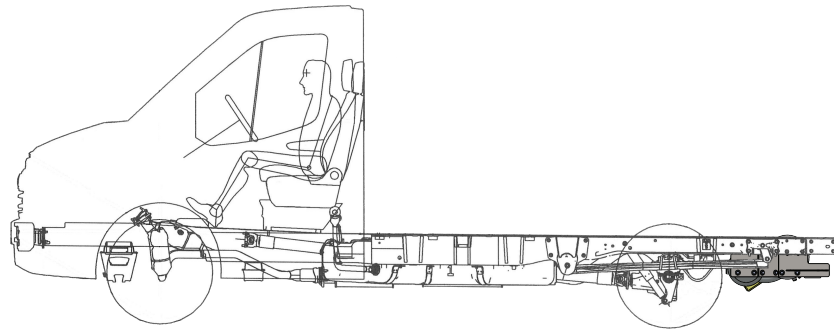

12 x 30 - 10 x 30.5 Fuel Tank - 17.5 USG
*Note - Trailer hitch required

156" Wheelbase Van

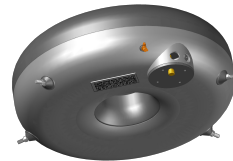
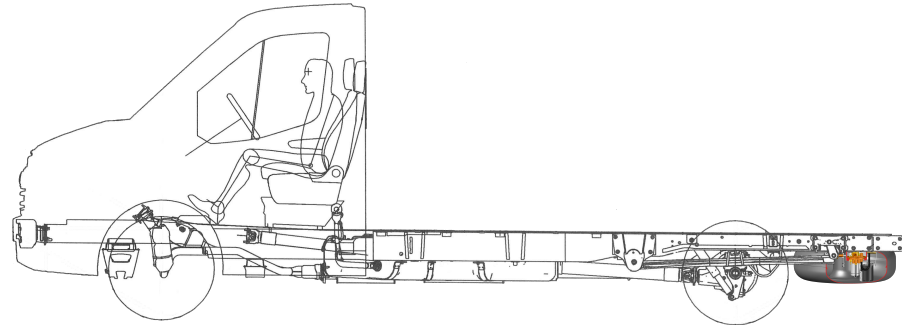

720 x 270 Fuel Tank - 19 USG
*Note - Trailer hitch required

178" Wheelbase Van

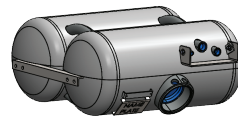
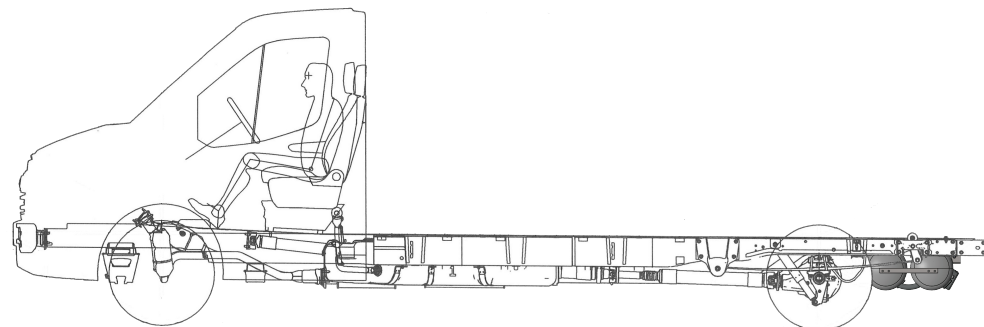

14 x 14 x 31 Fuel Tank - 28 USG
*Note - Trailer hitch required



54790 Grand River Avenue, New Hudson MI. 48165
Phone: 248-573-4934
www.icomnorthamerica.com
email: info@icomnorthamerica.com

The ICOM JTG® II Bi Fuel Propane Liquid Injection System is EPA Certified for the Ford 3.5L and 3.7L Transit Wagon / Van.

Go Green and Dramatically Reduce Fuel Costs!



Optional - ICOM's 'Propane Optimization Program' (POP) eliminates driver input to maximize propane usage

The patented ICOM JTG® II Propane Liquid Injection System is innovative and offers these advantages:

- Nationwide Installation and Service
- Equal power, torque and drivability of gasoline
- Cold climate reliability
- Reduces greenhouse gas emissions by up to 20%
- Dramatically reduced emissions
- Virtually no particulates
- Fuel range extended with the use of bi-fuel
- Extended service intervals
- Vehicle warranty remains in effect



Transit Wagon

PASSENGER WAGON		BODY TYPES		
		T150	T350	T350
		130" WB	148" WB	148" WB (EXTENDED LENGTH BODY)
		SRW	SRW	DRW
FUEL TANKS	12 x 30 - 10 x 30.5 (17.5 USG)	X	X	-
	720 x 270 TOROIDAL (19 USG)	X	X	-
	13 x 13 x 32 (25.5 USG)	-	-	X
	14 x 14 x 31 (28 USG)	-	-	X

130" Wheelbase Wagon

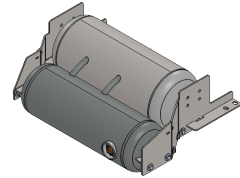
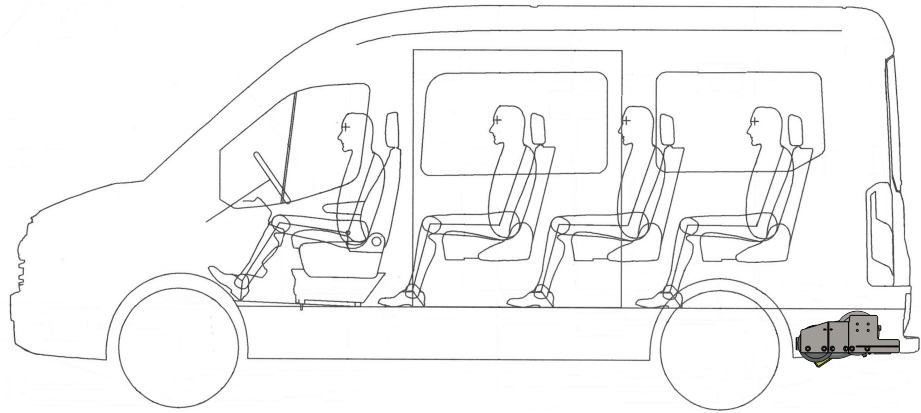

12 x 30 - 10 x 30.5 Fuel Tank - 17.5 USG
*Note - Trailer hitch required



720 x 270 Fuel Tank - 19 USG
*Note - Trailer hitch required

Transit Van

VAN		BODY TYPE (LOW ROOF)					
		T150	T150	T250	T250	T350	T350
		130" WB	148" WB	130" WB	148" WB	130" WB	148" WB
		SRW	SRW	SRW	SRW	SRW	SRW
FUEL TANKS	720 x 270 TOROIDAL (19 USG)	X	X	X	X	X	X
	12 x 30 - 10 x 30.5 (17.5 USG)	X	X	X	X	X	X

Low Roof

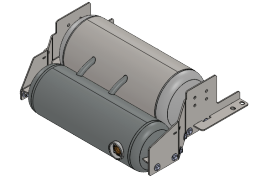
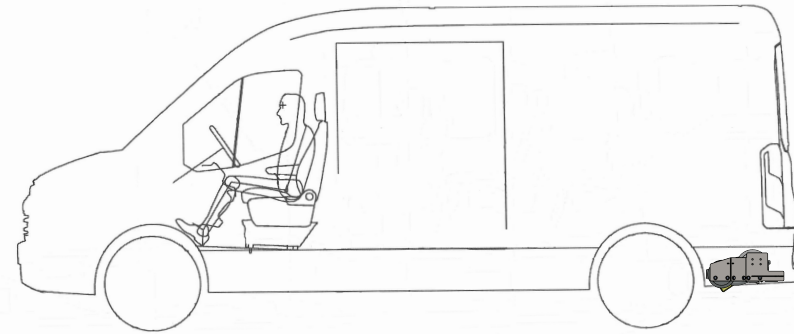

12 x 30 - 10 x 30.5 Fuel Tank - 17.5 USG
*Note - Trailer hitch required



720 x 270 Fuel Tank - 19 USG
*Note - Trailer hitch required

148" Wheelbase Wagon

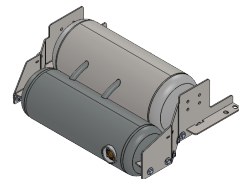
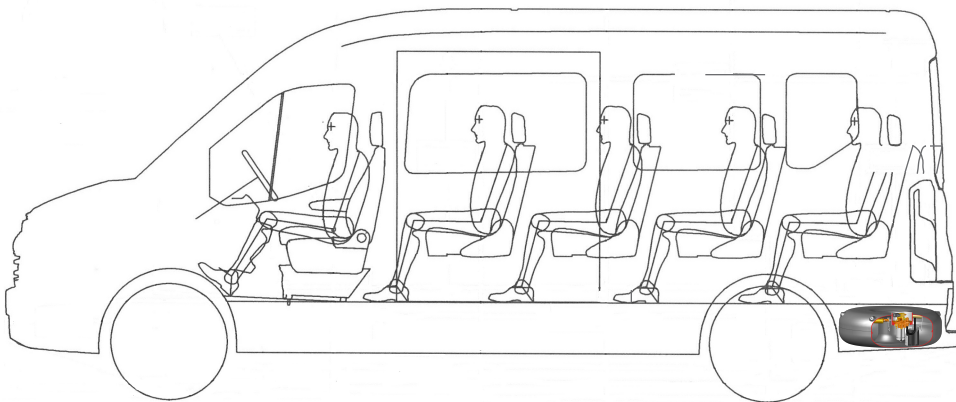

12 x 30 - 10 x 30.5 Fuel Tank - 17.5 USG
*Note - Trailer hitch required



720 x 270 Fuel Tank - 19 USG
*Note - Trailer hitch required

Medium Roof

VAN		BODY TYPE (MED ROOF)					
		T150	T150	T250	T250	T350	T350
		130" WB	148" WB	130" WB	148" WB	130" WB	148" WB
		SRW	SRW	SRW	SRW	SRW	SRW
FUEL TANKS	720 x 270 TOROIDAL (19 USG)	X	X	X	X	X	X
	12 x 30 - 10 x 30.5 (17.5 USG)	X	X	X	X	X	X

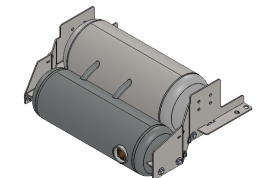
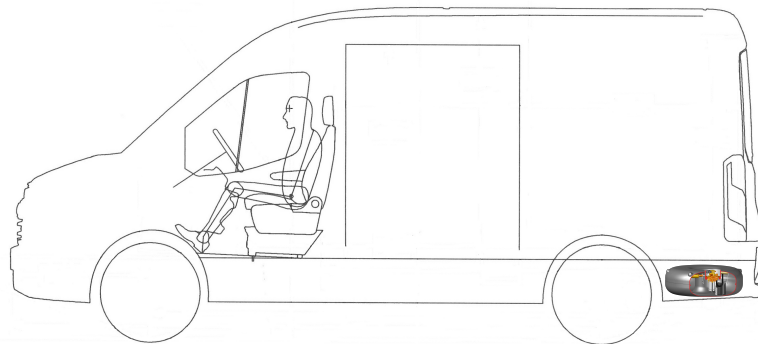

12 x 30 - 10 x 30.5 Fuel Tank - 17.5 USG
*Note - Trailer hitch required



720 x 270 Fuel Tank - 19 USG
*Note - Trailer hitch required

148" Wheelbase Wagon with Extended Length Body

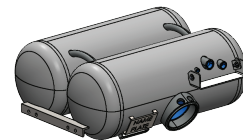
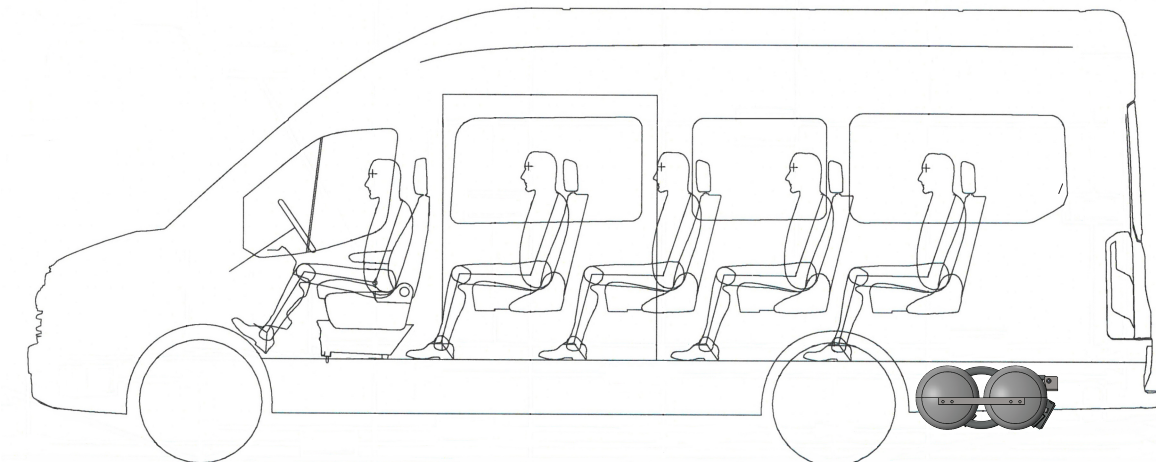

13 x 13 x 32 Fuel Tank - 25.5 USG
*Note - Trailer hitch required

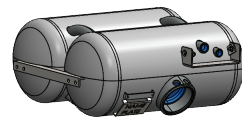

14 x 14 x 31 Fuel Tank - 28 USG
*Note - Trailer hitch required

High Roof

VAN		BODY TYPE (HIGH ROOF)				
		T250	T250	T350	T350	T350
		148" WB	148" W/ELB	148" WB	148" W/ELB	148" W/ELB
		SRW	SRW	SRW	SRW	DRW
FUEL TANKS	720 x 270 TOROIDAL (19 USG)	X	-	X	-	-
	12 x 30 - 10 x 30.5 (17.5 USG)	X	-	X	-	-
	13 x 13 x 32 (25.5 USG)	-	X	-	X	X
	14 x 14 x 31 (28 USG)	-	X	-	X	X

*Note - ELB (Extended Length Body)

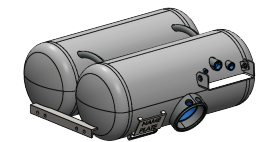
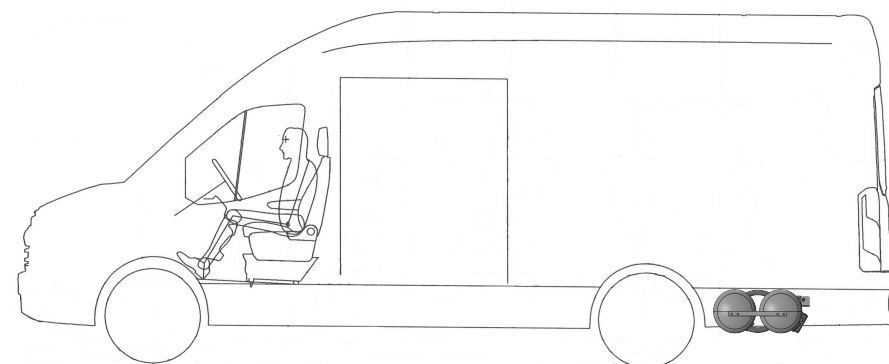

13 x 13 x 32 Fuel Tank - 25.5 USG
*Note - Trailer hitch required



14 x 14 x 31 Fuel Tank - 28 USG
*Note - Trailer hitch required